



# Standard Test Method for Leaching Solid Material in a Column Apparatus<sup>1</sup>

This standard is issued under the fixed designation D4874; the number immediately following the designation indicates the year of original adoption or, in the case of revision, the year of last revision. A number in parentheses indicates the year of last reapproval. A superscript epsilon ( $\epsilon$ ) indicates an editorial change since the last revision or reapproval.

## 1. Scope

1.1 This test method is a standard laboratory procedure for generating aqueous leachate from materials using a column apparatus. It provides a leachate suitable for organic analysis of semivolatile and nonvolatile compounds as well as inorganic analyses.

1.2 The column apparatus is designed and constructed of materials chosen to enhance the leaching of low concentrations of semivolatile and nonvolatile organic constituents as well as to maximize the leaching of metallic species from the solid. Analysis of column effluent provides information on the leaching characteristics of material under the conditions used in the test.

1.3 This test method provides for the passage of an aqueous fluid through materials of known mass in a saturated up-flow mode.

1.4 It is intended that the sample used in the procedure be physically, chemically, and biologically representative of the material.

1.5 This test method does not produce results that can be used as the sole basis for (1) engineering design of a disposal site, or (2) the characterization of wastes based on their leaching characteristics.

1.6 *This test method has the following limitations:*

1.6.1 Maximum particle size is 10 mm (0.4 in.). Particle size reduction is not recommended. Large-diameter material (cinders, rocks, and so forth) should be removed prior to packing the column to ensure adequate compaction.

1.6.2 Test materials containing densely immiscible organic material may result in phase separation and lead to column plugging.

1.6.3 This test method does not differentiate between dissolved constituents and sub-70- $\mu\text{m}$  particulates that pass through the pores of the end plates.

1.6.4 This test method is not applicable to the leachability characterization of materials with regard to volatile compounds.

1.6.5 This test method is not applicable to the characterization of materials that dissolve in water to a degree that significantly impacts the void volume in the column or the determination of the specific gravity of the material.

1.7 Application of this test method to materials with initial low permeability, or to those that lose permeability over the course of the test, may result in long testing periods.

1.8 The values stated in SI units are to be regarded as the standard. The values given in parentheses are in approximate inch-pound equivalents.

1.9 *This standard does not purport to address all of the safety concerns, if any, associated with its use. It is the responsibility of the user of this standard to establish appropriate safety and health practices and determine the applicability of regulatory limitations prior to use.*

## 2. Referenced Documents

2.1 *ASTM Standards:*<sup>2</sup>

[C819 Test Method for Specific Surface Area of Carbon or Graphite \(Withdrawn 1987\)](#)<sup>3</sup>

[D422 Test Method for Particle-Size Analysis of Soils](#)

[D698 Test Methods for Laboratory Compaction Characteristics of Soil Using Standard Effort \(12 400 ft-lbf/ft<sup>3</sup> \(600 kN-m/m<sup>3</sup>\)\)](#)

[D854 Test Methods for Specific Gravity of Soil Solids by Water Pycnometer](#)

[D1125 Test Methods for Electrical Conductivity and Resistivity of Water](#)

[D1129 Terminology Relating to Water](#)

[D1293 Test Methods for pH of Water](#)

[D1498 Test Method for Oxidation-Reduction Potential of Water](#)

[D1888 Methods Of Test for Particulate and Dissolved Matter in Water \(Withdrawn 1989\)](#)<sup>3</sup>

<sup>1</sup> This test method is under the jurisdiction of ASTM Committee D34 on Waste Management and is the direct responsibility of Subcommittee D34.01.04 on Waste Leaching Techniques.

Current edition approved May 1, 2014. Published May 2014. Originally approved in 1989. Last previous edition approved in 2006 as D4874 – 95(2006). DOI: 10.1520/D4874-95R14.

<sup>2</sup> For referenced ASTM standards, visit the ASTM website, [www.astm.org](http://www.astm.org), or contact ASTM Customer Service at [service@astm.org](mailto:service@astm.org). For *Annual Book of ASTM Standards* volume information, refer to the standard's Document Summary page on the ASTM website.

<sup>3</sup> The last approved version of this historical standard is referenced on [www.astm.org](http://www.astm.org).

- D2216 Test Methods for Laboratory Determination of Water (Moisture) Content of Soil and Rock by Mass
- D2434 Test Method for Permeability of Granular Soils (Constant Head)
- D3370 Practices for Sampling Water from Closed Conduits
- D3694 Practices for Preparation of Sample Containers and for Preservation of Organic Constituents
- D4253 Test Methods for Maximum Index Density and Unit Weight of Soils Using a Vibratory Table
- E691 Practice for Conducting an Interlaboratory Study to Determine the Precision of a Test Method

### 3. Terminology

#### 3.1 Definitions:

- 3.1.1 *reagent water*—as defined in SW-846, Method 1311, 5.2.<sup>4</sup>

<sup>4</sup> SW-846, 3rd ed., Method 1311, Available from USEPA, Office of Solid Waste and Emergency Response, Washington, DC 20460.

3.1.2 *void volume*—the volume between the solid particles in a bed of granular material. Also called the interstitial volume.

3.2 Several terms used in this test method are defined in Terminology D1129.

### 4. Significance and Use

4.1 This test method is intended to provide an aqueous leaching of a material in a dynamic partitioning manner.

4.2 Specific operating conditions for the column can be selected to satisfy the objectives of individual studies. An understanding of the fundamental principles governing column leaching is necessary in the selection of appropriate conditions. References (1-3)<sup>5</sup> provide useful information on these principles.

<sup>5</sup> The boldface numbers in parentheses refer to the list of references at the end of this standard.

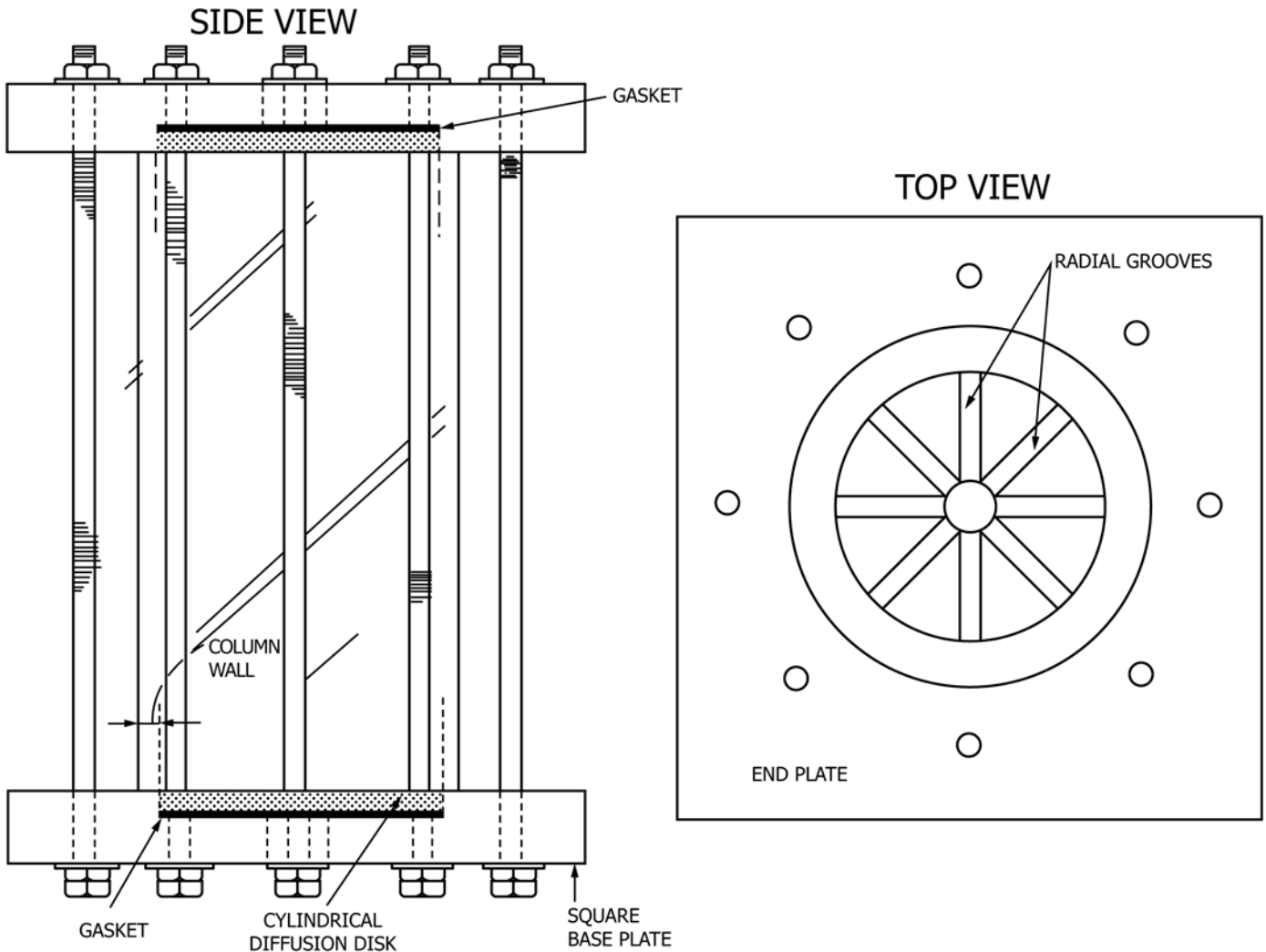

FIG. 1 Column Apparatus

4.3 The column apparatus is constructed of materials that permit the generation of a leachate which is suitable for low concentration organic analysis for semivolatile and nonvolatile compounds as well as inorganic species.

## 5. Apparatus (See Fig. 1)

### 5.1 Columns:

5.1.1 The column body is constructed of glass pipe, 300 mm (12 in.) in length, with an inside diameter of 100 mm (4 in.). The cylinder wall must be of sufficient thickness, approximately 6 mm ( $\frac{1}{4}$  in.), to withstand the operating pressure.

5.1.2 End plates are constructed of stainless steel. They are attached by means of eight, 6-mm ( $\frac{1}{4}$ -in.) threaded rods or any other means which ensures a leakproof seal.

5.1.3 Gaskets, one at each end of the column, are constructed of chemically inert materials, and are as thin as possible while still providing a good seal. The gasket diameter should overlap the inside column diameter by 3 mm ( $\frac{1}{8}$  in.) to prevent the gasket from being forced out while under pressure. Techniques other than gaskets for providing a seal between the column and end plates are allowed provided the technique used is specified in the report.

5.1.4 Flow distribution disks must be constructed of sintered stainless steel, with a nominal pore diameter of 70  $\mu\text{m}$ . The disk thickness shall be 6 mm ( $\frac{1}{4}$  in.), with a diameter equal to the inside diameter of the column, approximately 100 mm (4 in.). The disk shall have eight evenly spaced grooves; each of which is 3 mm ( $\frac{1}{8}$  in.) wide, 3 mm deep and 50 mm (2 in.) long. These grooves shall be positioned in a ray originating from the center of the disk.

5.1.5 Tubing used in the apparatus shall be of inert materials, for example, glass, stainless steel, polytetrafluoroethylene lined. The outer diameter shall be 6 mm ( $\frac{1}{4}$  in.).

5.1.6 Substitution of materials of construction of the column or any of its parts is acceptable, as long as it is demonstrated that levels of contamination for analyte(s) of interest are equal to or less than those specified. Any modification of the apparatus as described in this test method must be justified, documented, and delineated in the report.

5.2 *Pressurized Reservoir Vessel*, which is used to contain the leaching fluid, is constructed with requirements similar to those of the leaching column with the following exceptions: (1) no diffusion disks are used, and (2) it is equipped with a top port for refilling the fluid.

5.3 *Balance*, 10-kg capacity, with a 1-g sensitivity.

5.4 *Compressed Gas Source*, prepurified nitrogen or argon with a two-stage delivery regulator (0 to 350 kPa) (0 to 50 psig), and a pressure gauge capable of measuring the pressure in the head space of the liquid reservoir to within  $\pm 7$  kPa (1 psig).

## 6. Reagents and Materials

6.1 American Chemical Society (ACS) Reagent grade chemicals or equivalent are preferred.<sup>6</sup>

6.2 Other grades of chemicals may be used, provided that the reagent is of sufficiently high purity to permit its use without compromising the objectives of the testing.

6.3 Demonstration of acceptability through reagent blank data at or below the quantitation limits for all analytes of interest is required.

6.4 Unless otherwise indicated, references to reagent water mean water as defined in SW-846, Method 1311, 5.2. See reagent water under the terminology section of this test method (3.1.1).

NOTE 1—Reagent water is defined in SW-846 as water in which an interferant is not observed at or above the method's detection limit of the analyte(s) of interest.

## 7. Safety Precaution

7.1 General operating pressure should not exceed 275.8 kPa (40 psig) with materials as defined herein. Other inert materials are available that can be used to manufacture the column which will withstand pressures above 275.8 kPa (40 psig).

## 8. Sampling

8.1 Sampling must be performed so as to obtain a representative sample of the material.

8.2 Where no specific sampling methods are available, sampling methods for materials of physical form similar to the material shall be used.

8.3 A minimum sample of 5000 g, or three column volumes, whichever is larger, shall be sent to the laboratory for each column.

8.4 Samples must be kept in closed containers appropriate to the sample type and otherwise protected if necessary prior to testing to prevent sample contamination or constituent change or loss. Where it is desired to test biologically or chemically active samples in their existing state, any sample storage required should be at 4°C (Practice D3370) and the leaching should be started within 8 h of sample collection. Where appropriate, the tester may modify a test portion before leaching to simulate the results of biological or chemical activity in the field. Record the storage conditions, sampling procedures, handling practices, and any abnormal sampling conditions in the report.

<sup>6</sup> *Reagent Chemicals, American Chemical Society Specifications*, American Chemical Society, Washington, DC. For suggestions on the testing of reagents not listed by the American Chemical Society, see *Analar Standards for Laboratory Chemicals*, BDH Ltd., Poole, Dorset, U.K., and the *United States Pharmacopeia and National Formulary*, U.S. Pharmacopeial Convention, Inc. (USPC), Rockville, MD.